

新產品 - 疊加式節流閥 Throttle Modular Valves

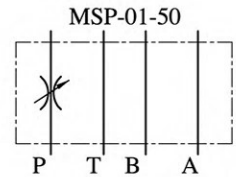

選購指南 HOW TO ORDER

MSP	-	01	-	50
系列編號 SERIES NUMBER		口徑 VALVE SIZE		設計號 DESIGN NUMBER
Throttle Modular Valves				
MSP : For P - Line		- 01 : 1/4"		- 50

規格說明 SPECIFICATIONS

型式 Model Series	最高使用壓力 Max. Operated Pressure MPa (kgf/cm ²)	最大流量 Max. Flow (L/min)	重量 Weight (kg)
MSP-01-50	31.5 (315)	60 *1	1.2

*1 Maximum flow decreases when the differential pressure is less than 1.5 MPa (15 kgf/cm²).
See "Pressure Drop at Spool fully Open"

性能曲線 PERFORMANCE CURVES

Hydraulic Fluid : Viscosity 35 cSt (35 mm²/s) , Specific Gravity 0.850

調整輪全開時壓力降特性
Pressure Drop at Spool Fully Open (P-Line)

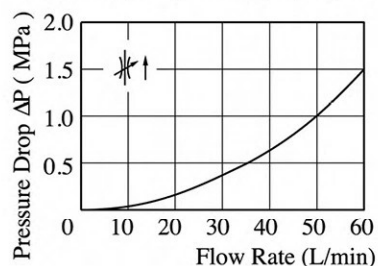

壓力降特性
Pressure Drop

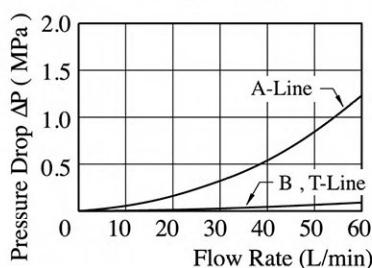

開度-流量特性
Metred Flow vs. Dial Position
ΔP : Differential Pressure (MPa)

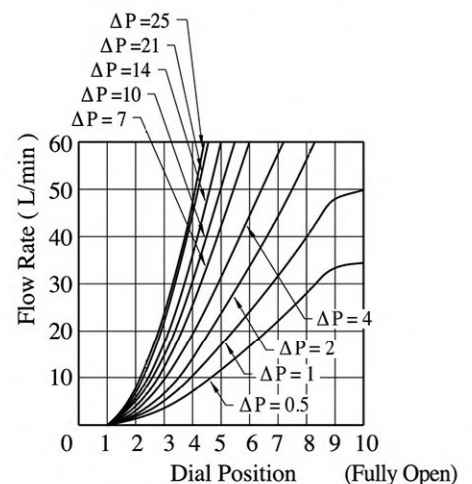

疊加式節流閥 Throttle Modular Valves

● MSP-01

安裝尺寸符合ISO4401-AB-03-4-A
Mounting Surface:ISO4401-AB-03-4-A

DIMENSIONS IN MILLIMETRES

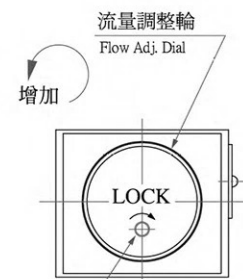
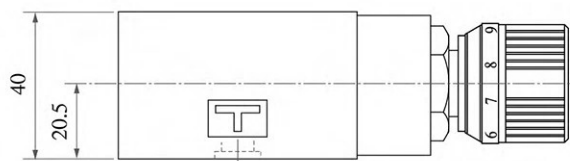
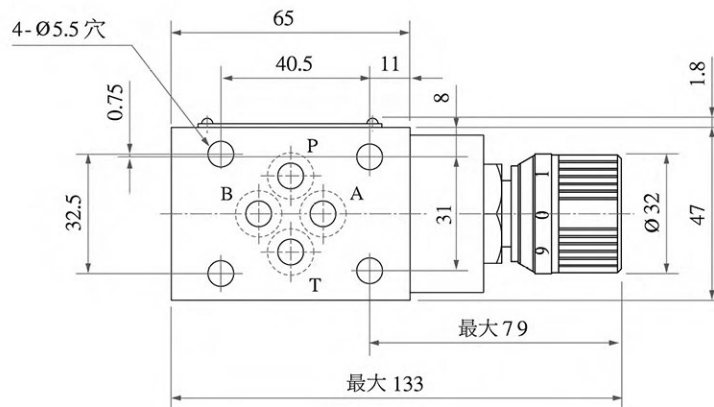

調整輪固定螺絲 Locking Screw
六角孔對邊 2 Hex. Soc.